

TALLER DE

GDL

filamento

MEX

LUMINARIAS
ARTESANALES

filamento



FILAMENTO ES UN ESTUDIO Y TALLER DE LUMINARIAS
FUNDADO EN 2015 EN GUADALAJARA QUE ENTREMEZCLA
EL DISEÑO CONTEMPORÁNEO CON LA TRADICIÓN
POPULAR DEL ARTE MEXICANO.



El taller nació de una necesidad en particular: la de iluminar el espacio desde la autenticidad. Una autenticidad ligada a las manos de los artesanos que trabajan a detalle materiales endémicos, los cuales nos narran la historia de los orígenes, antepasados, costumbres e identidad de cada región artesanal.

Asimismo, la labor de Filamento impacta en los flujos económicos de las familias artesanas. Con un modelo de comercio justo, las colaboraciones con las y los artesanos son de respeto a la tradición y el legado familiar. Esto otorga un valor comercial particular a las piezas aportando al desarrollo del arte popular en diferentes comunidades mexicanas..





TÉCNICA:

COBRE MARTILLADO

COLECCIÓN PURÉPECHA

La gama de colecciones de Filamento representa un mapa de las regiones profundamente artesanales del Occidente de México. De la región tarasca, en el estado de Michoacán, brotan a golpes las piezas de cobre martillado. Una técnica original y que aún se mantiene vigente en el poblado de Santa Clara de Cobre, reconocido a nivel mundial por trabajar este mineral con la pasión de quien hereda los conocimientos familiares y ancestrales.

La idea central de la Colección Purépecha gira en torno a las marcas que deja cada artesano sobre las placas de cobre, para así alejarse de la estandarización industrial y apreciar en cada hendidura del martillo un gesto y un detalle particular.

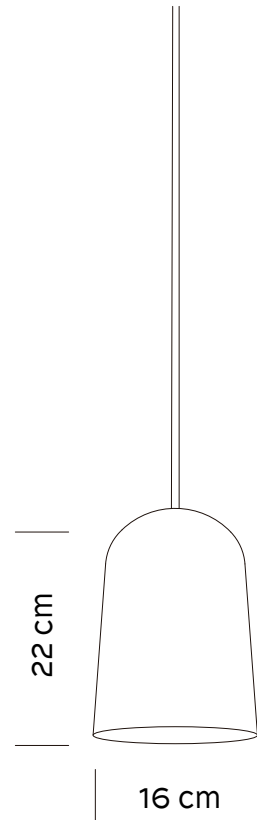

ACABADOS



CLARA

CLARA II

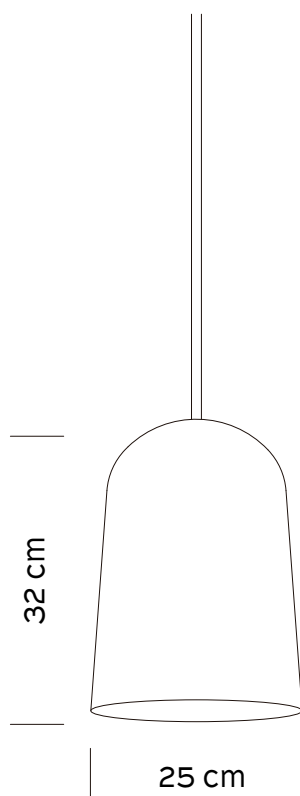

ACABADOS



PL



B-T



DA



PL-R



QU



DA-R



AH



QU-R



OX1



AH-R



OX2



OX1-R



OX3



OX2-R



N-T



OX3-R





OCAMPO

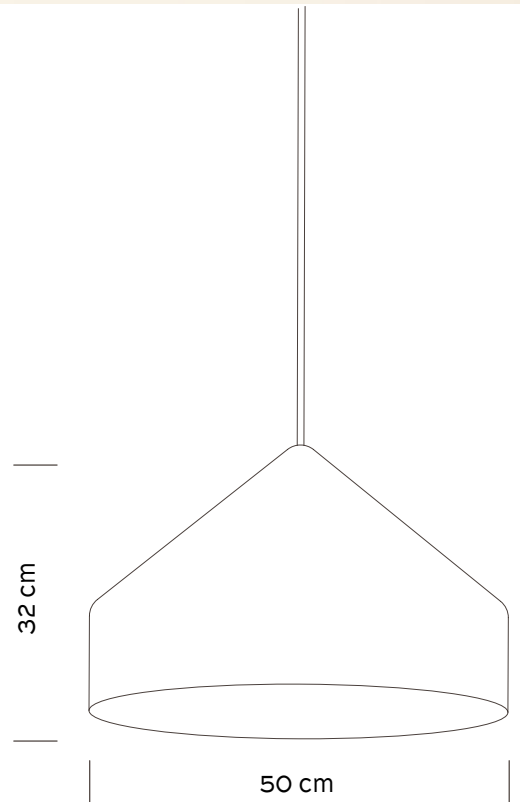

ACABADOS



CAPULA

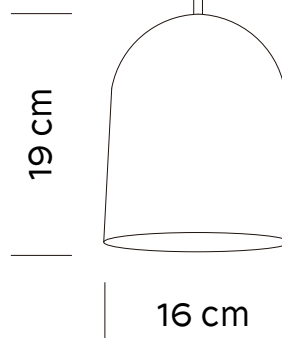

ACABADOS



PL



B-T



DA



PL-R



QU



DA-R



AH



QU-R



OX1



AH-R



OX2



OX1-R



OX3



OX2-R



N-T



OX3-R



PALTA I

ACABADOS

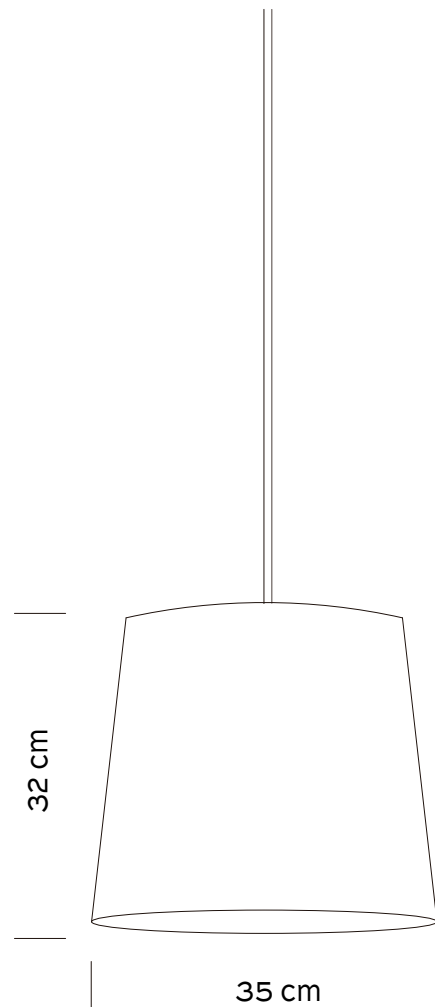

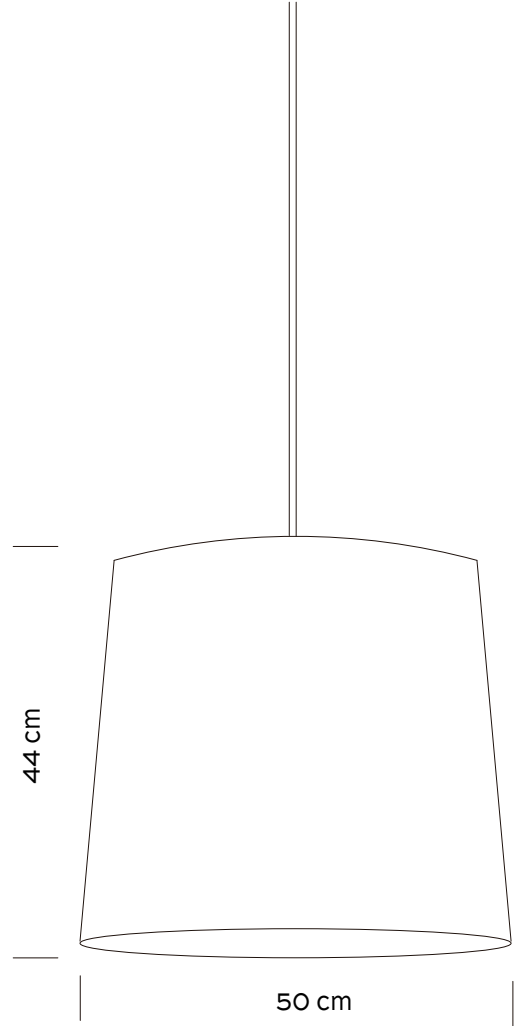

PALTA II

ACABADOS



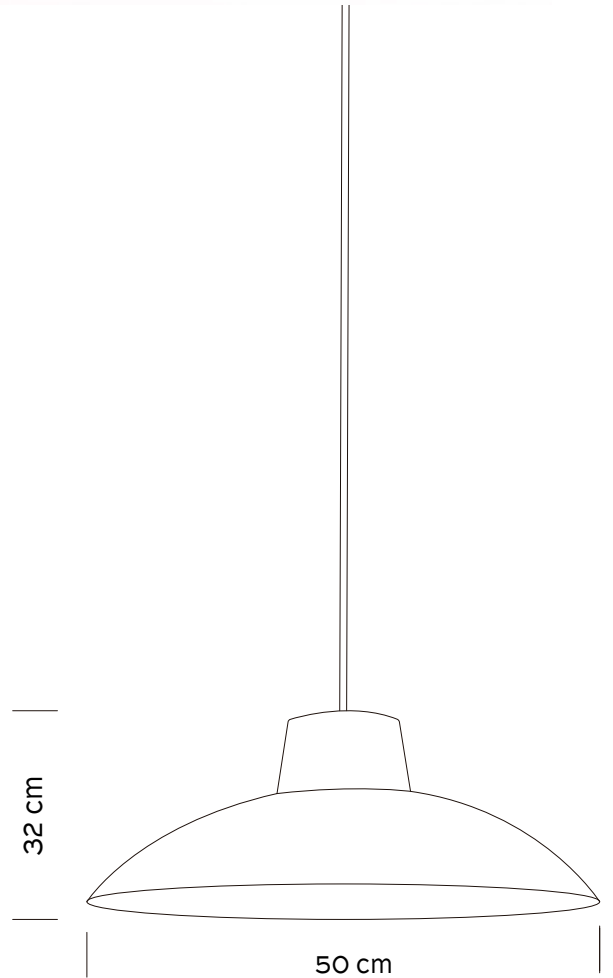

TIZÓN

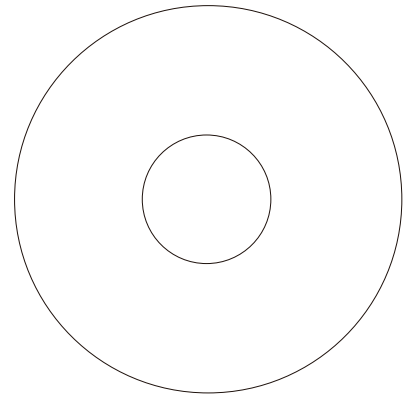

Ø25 cm

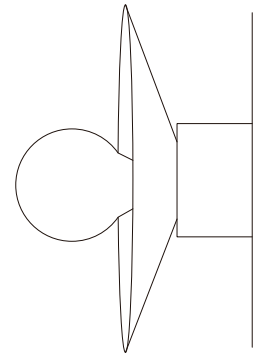

17 cm

VASCAI

ACABADOS

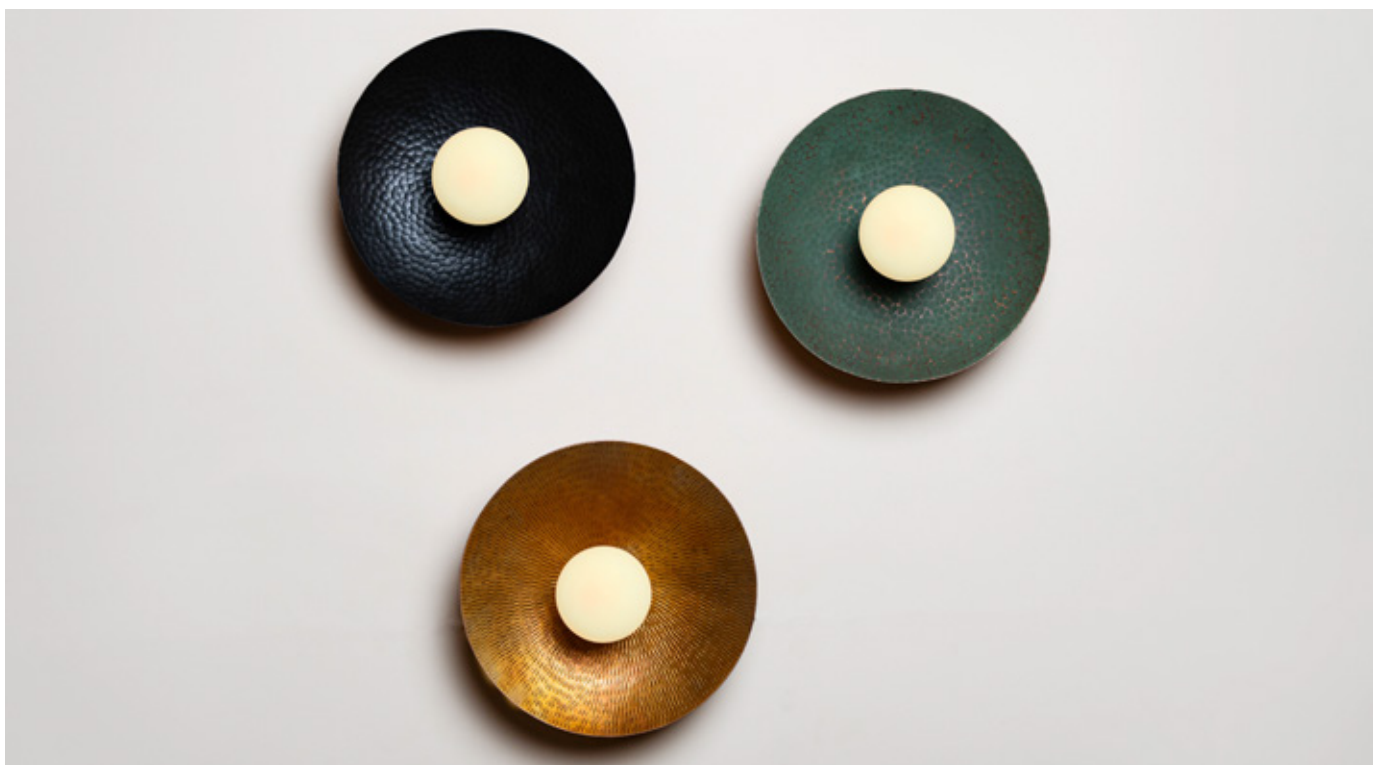

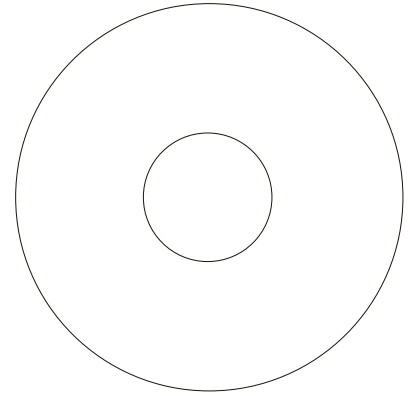

Ø50 cm

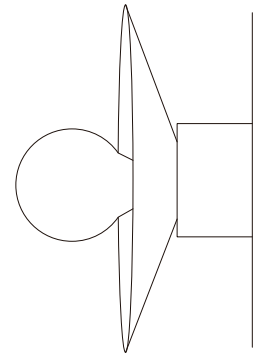

24 cm

VASCA II

ACABADOS



PL DA QU AH OX1 OX2 OX3 N-T B-T PL-R DA-R QU-R AH-R OX1-R OX2-R OX3-R



PUPA

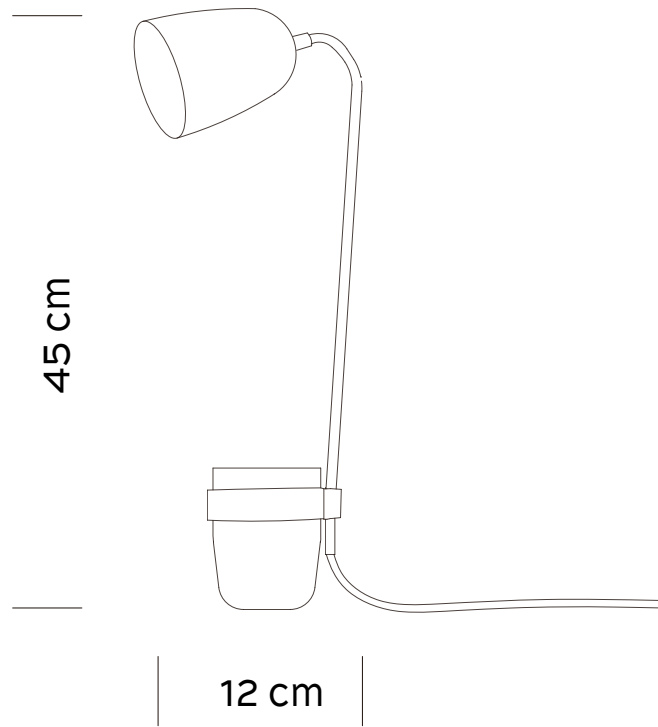

ACABADO

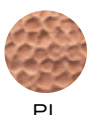

PL



TATA

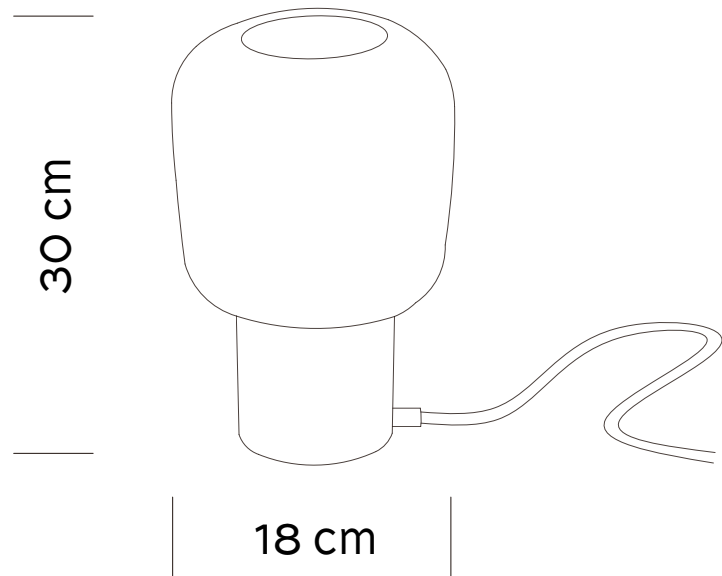

ACABADOS

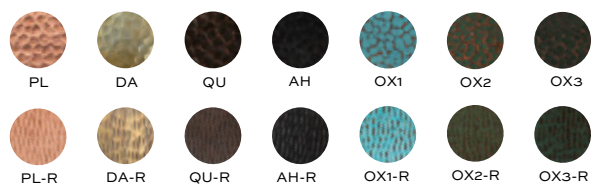

VOLCÁN

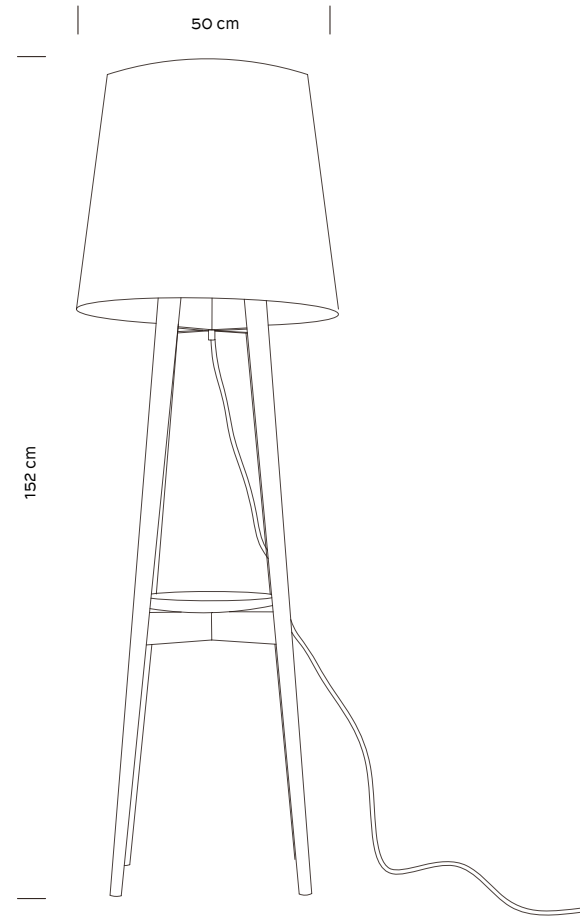

ACABADOS





TÉCNICA:

C H U S P A T A

COLECCIÓN JANITZIO

La Colección Janitzio, también michoacana, trabaja con un material tan flexible como endémico: las fibras naturales. Las manos artesanas que trabajan estas piezas rescatan los conocimientos ancestrales de las familias que han habitado en los alrededores del lago de Pátzcuaro para de ahí transformar el junco acuático en objetos fascinantes.

De la mano del maestro artesano, Rogelio Rojas, se han conformado diversos modelos que replican la técnica de entrelazar fibra con fibra para lograr piezas únicas. Lo más interesante de esta colección es que la luminaria se vuelve esencial al momento de diseñar la ambientación del espacio, ya que la luz se refleja según los huecos y las sombras de cada pieza.

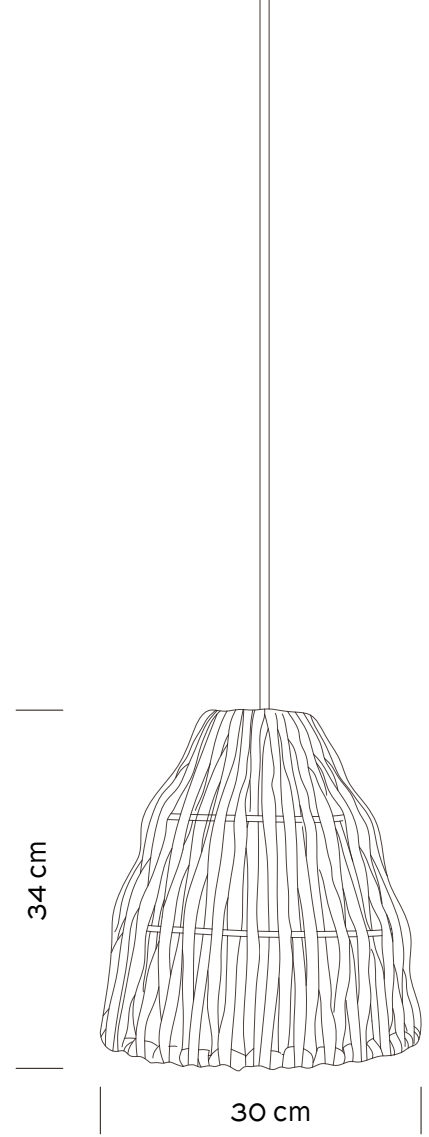

JUNCALI





JUNCAL II



JUNCAL III

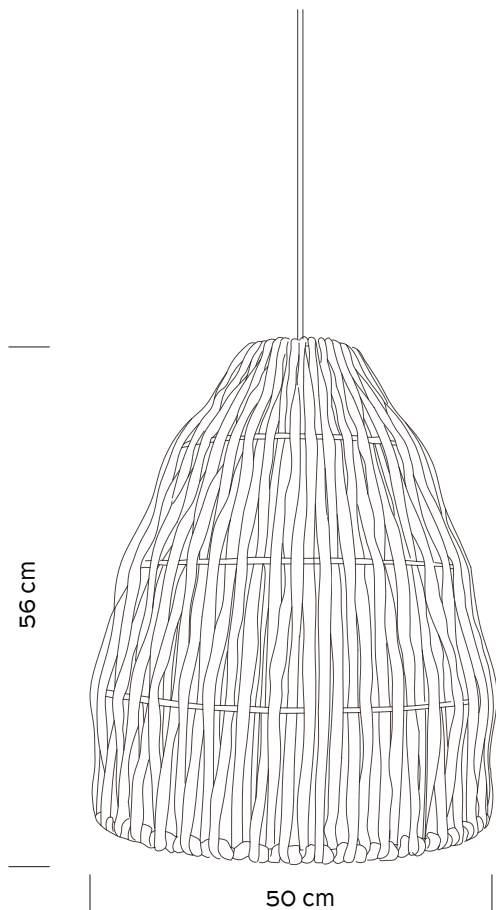

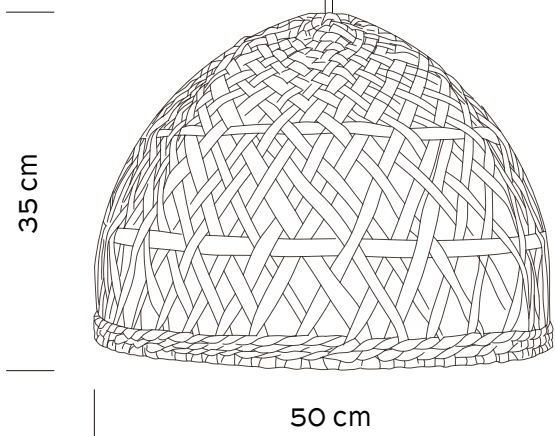

LUNA





TARASCA

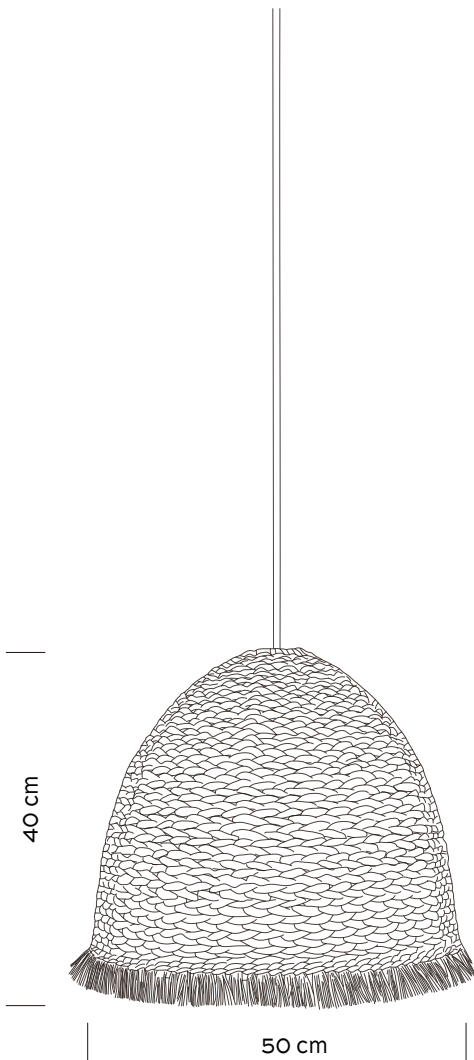

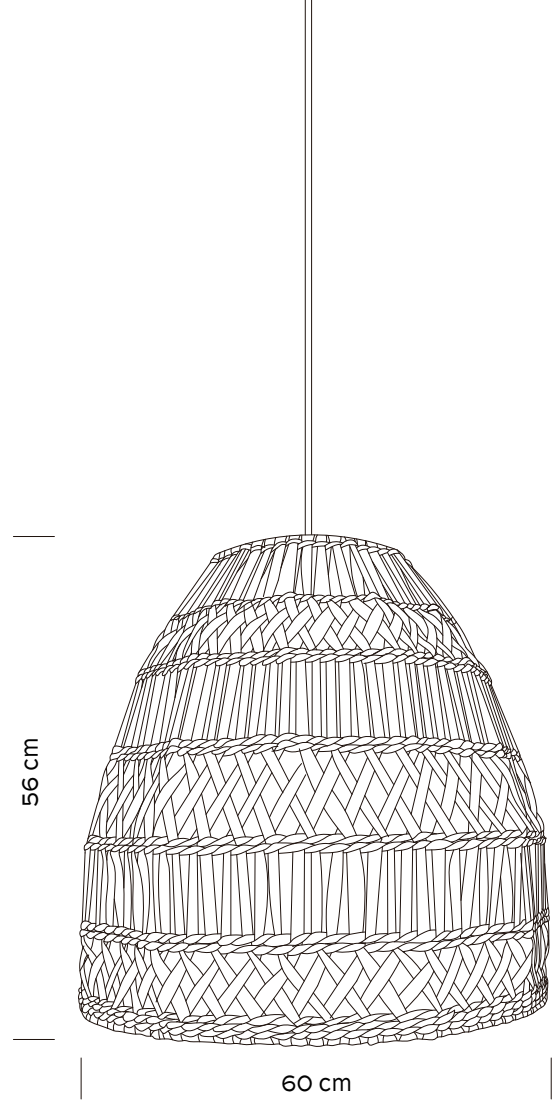

MARUATA



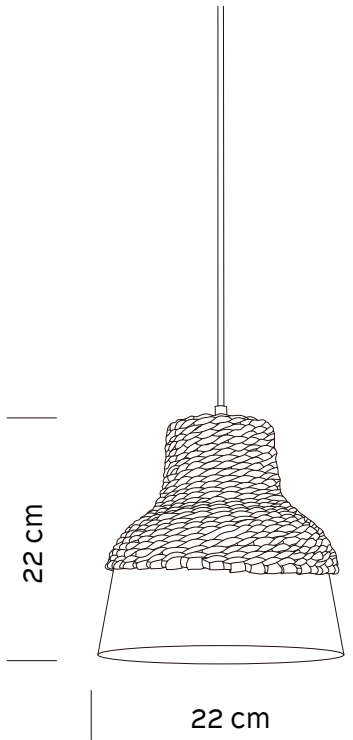

LAGUNA



ACABADOS

T-CA T-EN

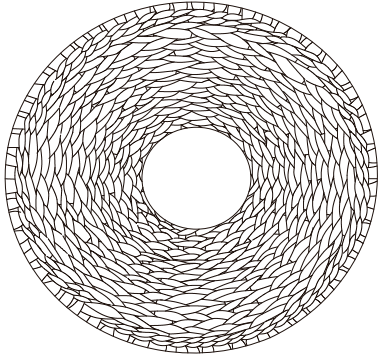

Ø32 cm

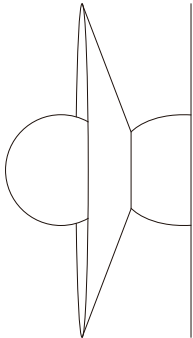

18 cm

CUITZEO I



ACABADOS

T-CA T-EN

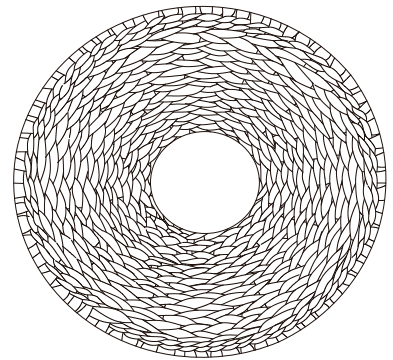

Ø50 cm

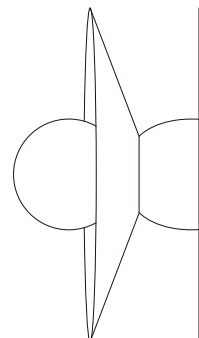

22 cm

CUITZEO II

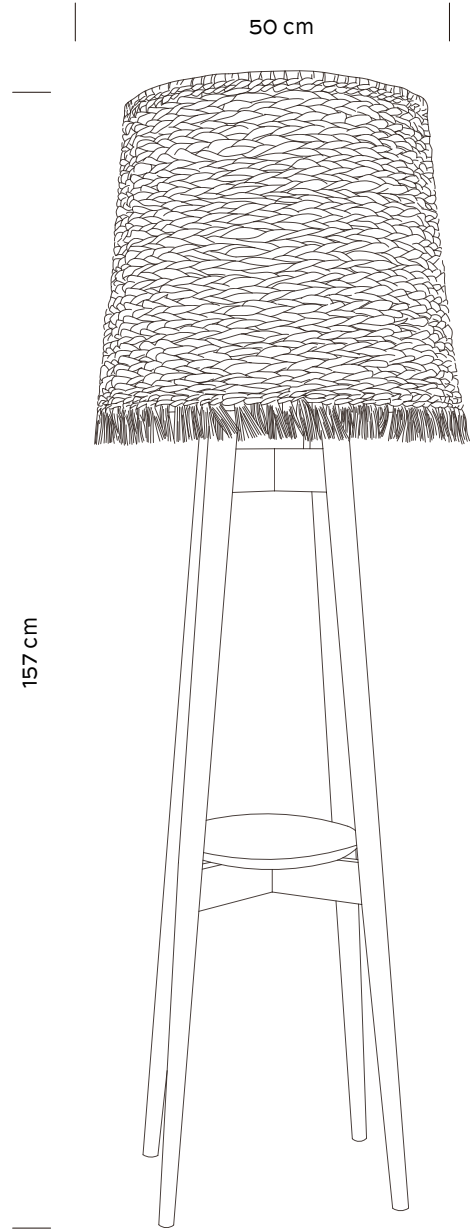

BALSA



TÉCNICA:

BARRO BRUÑIDO

COLECCIÓN TASTOÁN

Dentro de las colecciones, no podía faltar aquella que trabaja con el legado material y técnico del arte popular jalisciense, en particular del pueblo tastoán en Tonalá, su “cuna alfarera”. Las piezas de esta colección se acompañan del saber y la experiencia de Ángel Santos, maestro artesano de barro bruñido, cuya trayectoria ha sido reconocida a nivel mundial.

La característica principal de esta colección es su capacidad de llevar al diseño contemporáneo una técnica milenaria con lo cual se preserva la tradición tonalteca al tiempo que se abona a la vigencia del arte popular mexicano. Son piezas sinceras, que remiten al origen del barro: la ligereza de la tierra, tonalidades cálidas y pardas, las marcas caprichosas del fuego que deja todo paso por el horno.



ARENAL

ACABADOS

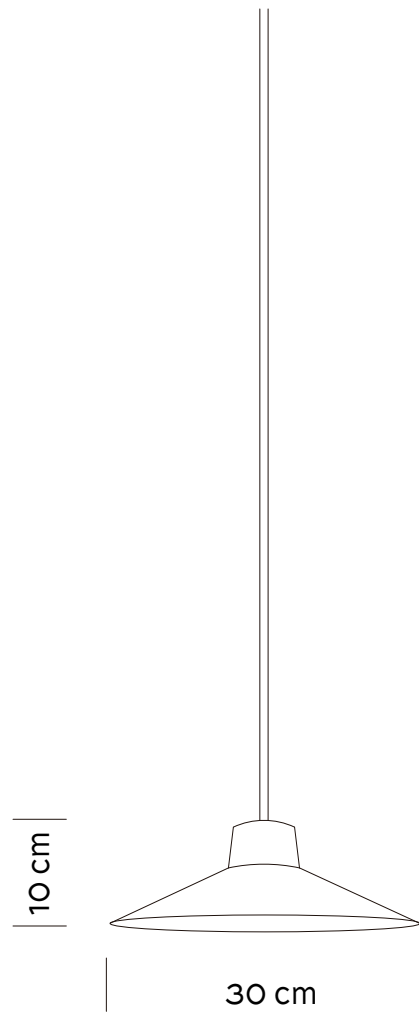

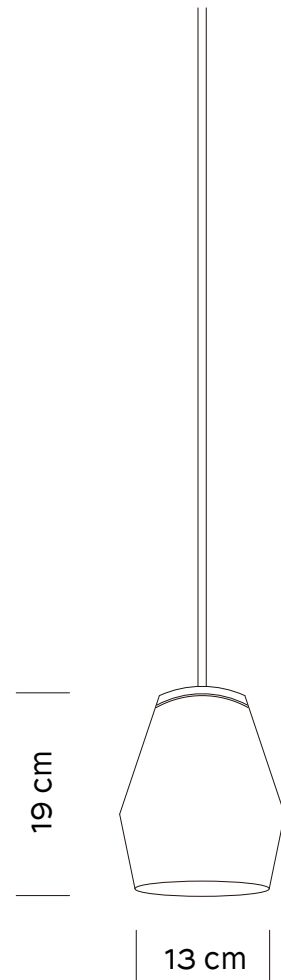

ACABADOS



NAHUAL



SIERRA I

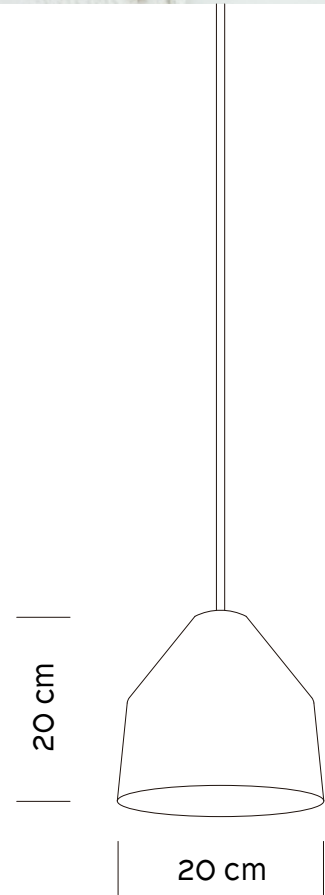

ACABADOS



BN-B

BN-M

GR-B

MT-M



SIERRA II

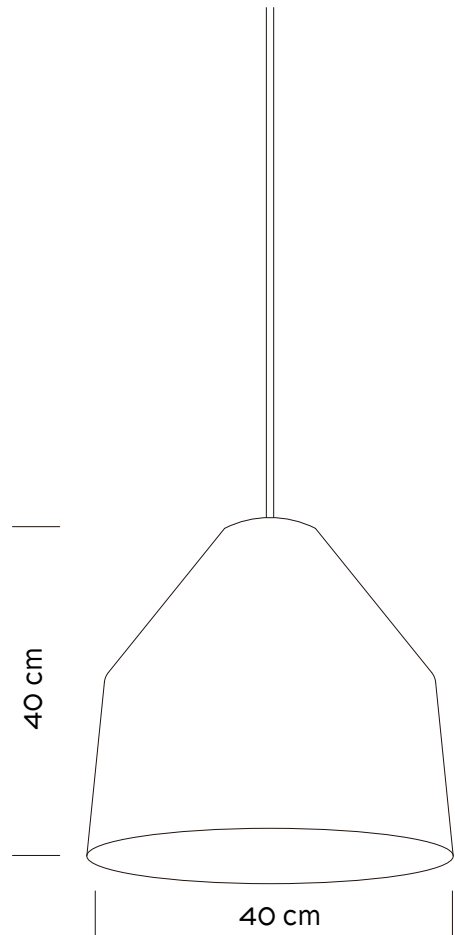

ACABADOS



BN-B

BN-M

GR-B

MT-M

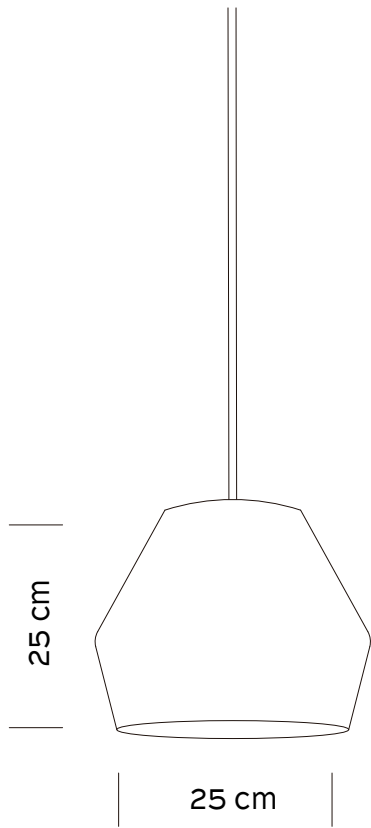

ACABADOS



MESTIZA



ARENAL ARB

ACABADOS

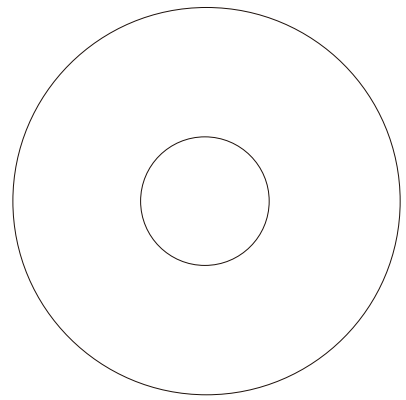

Ø32 cm

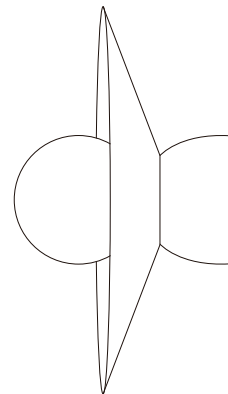

18 cm

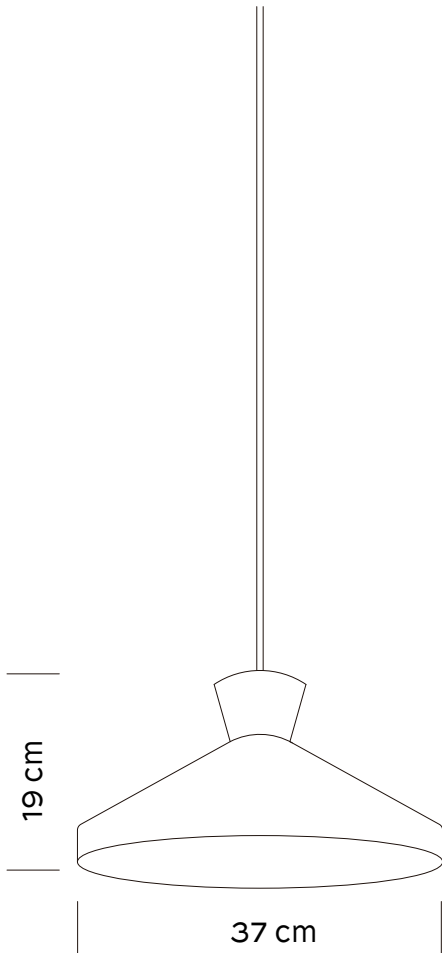

OCCIDENTE

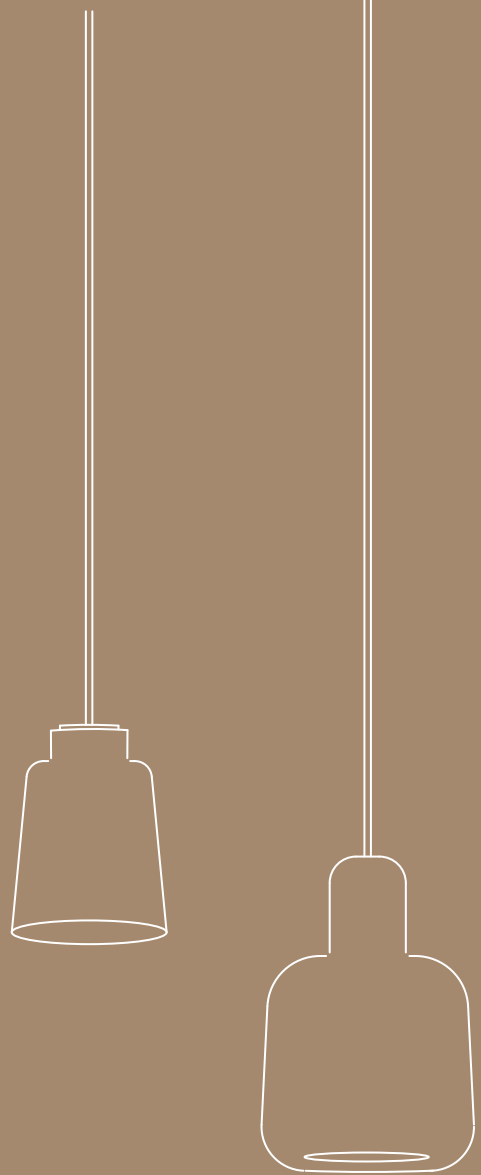

TÉCNICA:

VIDRIO SOPLADO

COLECCIÓN TONALTECA

Además, la Colección Tastoán se complementa de una línea de luminarias que aprovecha otra de las técnicas ancestrales de Tonalá: el vidrio soplado. En el proceso de creación de cada luminaria se involucran hasta cinco artesanos, cada cual con una tarea específica para cuidar los detalles de composición y diseño.

La originalidad es lo que define a estas piezas, pues si bien obedecen a un diseño contemporáneo, siempre habrá detalles particulares para diferenciarlas, ya que la forma de cada una de ellas depende del soplado único de los maestros vidrieros.

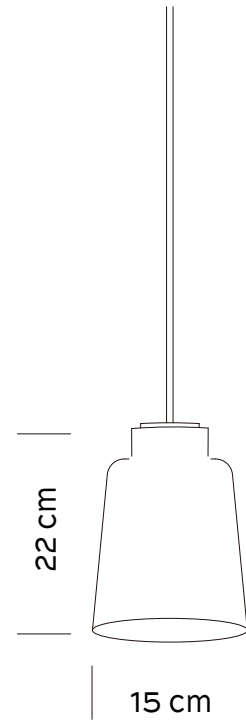

HUMO

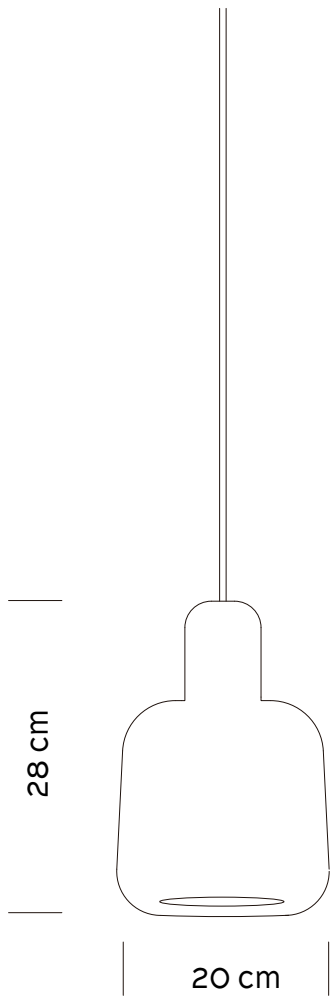

BRASA

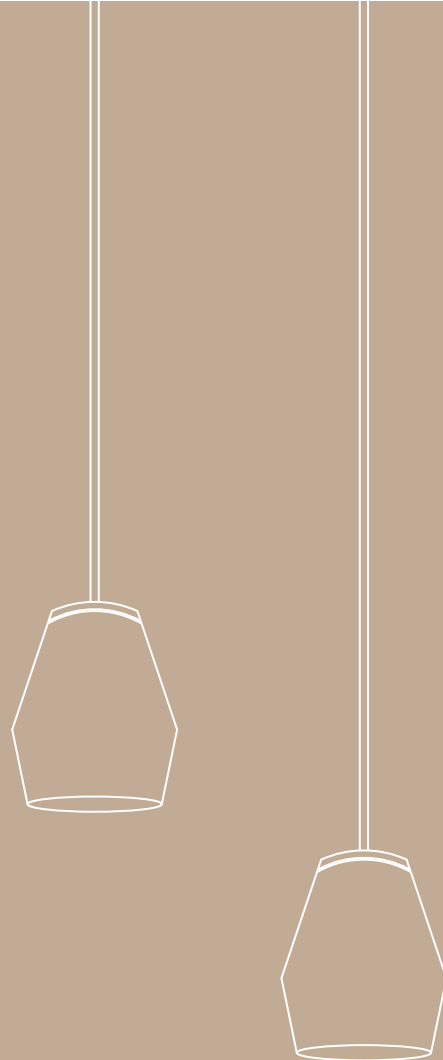

TÉCNICA:

PIEDRA VOLCÁNICA

COLECCIÓN SAN LUCAS

También en Jalisco, en el municipio de Tlajomulco, se encuentra el poblado de San Lucas Evangelista, cuyas familias artesanas se han especializado en trabajar la piedra volcánica. Este material es icónico en México pues con él se elaboran los molcajetes: esos morteros tradicionales de Mesoamérica que son ampliamente utilizados en la cocina mexicana. Al ser tan resistente, la piedra basáltica requiere de precisión técnica, así como

de un uso adecuado de las herramientas con las que se moldea, que en el caso de los maestros piedreros, pueden llegar a utilizar hasta 18 cinceles. Es tal la fuerza y el trabajo que requiere su diseño, que los artesanos pueden producir solamente tres piezas al día.

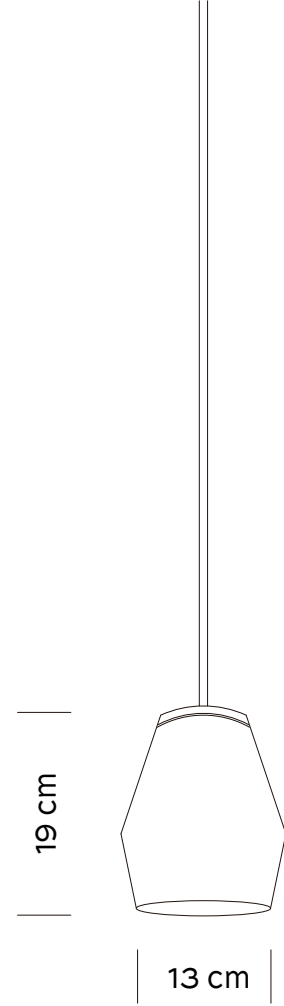

BAJIO



TÉCNICA:

TELAR DE PEDAL

COLECCIÓN CUPATITZIO

Cuando Filamento se propuso crear su nueva colección, era casi evidente que la siguiente técnica artesanal a explorar debía de ser el telar. Porque resulta innegable reconocer que en el vasto mundo del arte popular mexicano, el textil ocupa un lugar protagónico, que además cuenta con múltiples variantes según la región, la historia, el clima y los rituales que rodean a cada pueblo.

Fue en Uruapan que comenzó a gestarse la colección Cupatitzio de Filamento que, sin rodeos, debía hacer honor a las aguas que bañan todo el proceso artesanal detrás de cada luminaria. Fue ahí, también, donde comenzó a entretajarse cada urdimbre (el hilo vertical) y cada trama (el horizontal) en medio de un sinfín de posibilidades creativas para dar con el color, grosor y textura adecuadas.

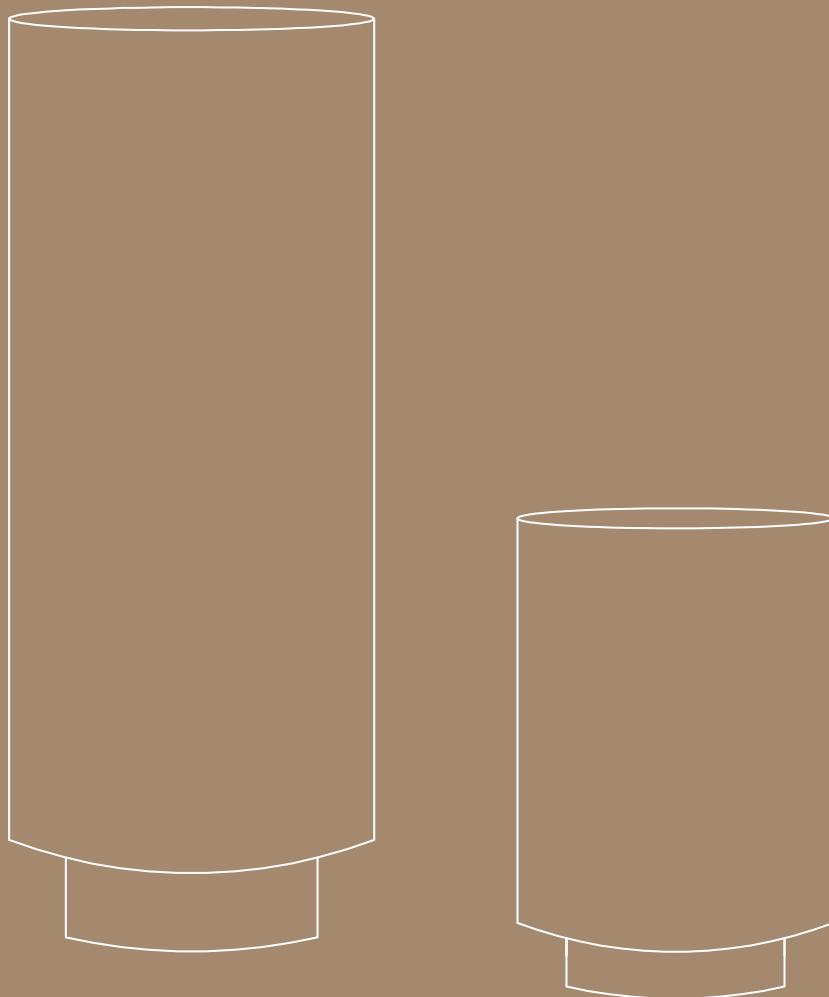

FLECOS EN CRUDO



FLECOS EN NEGRO



LINEAL EN AGAVE

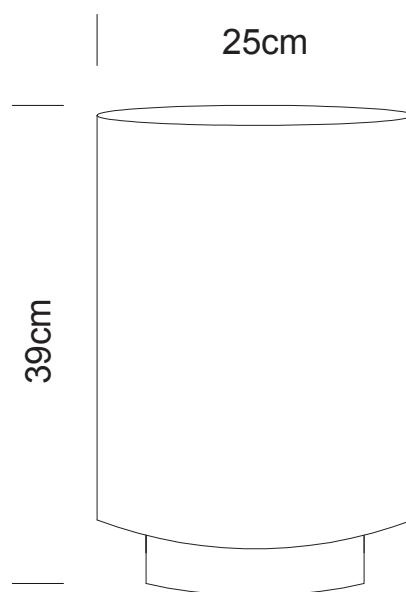

BASILIA

INTERCALADO EN AGAVE



CAMELIA I

ONDULADO EN CRUDO

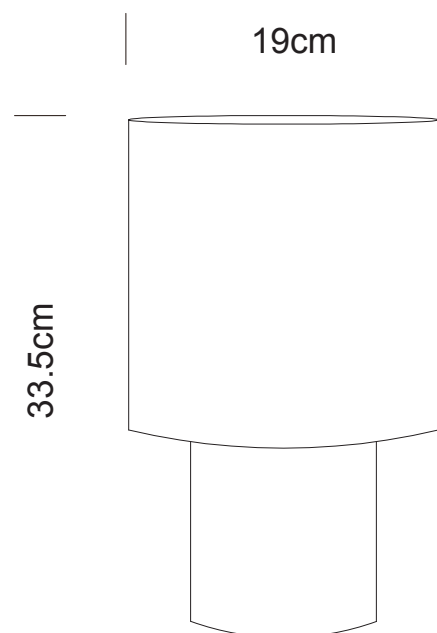

TUPIDO EN AGAVE



ONDULADO EN AGAVE



ONDULADO EN NEGRO



LINEAL EN AGAVE

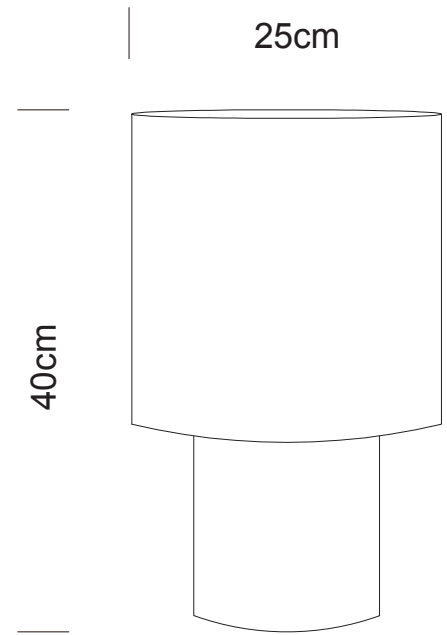

CAMELIA II

CASCADA EN CRUDO



ONDULADO EN CRUDO



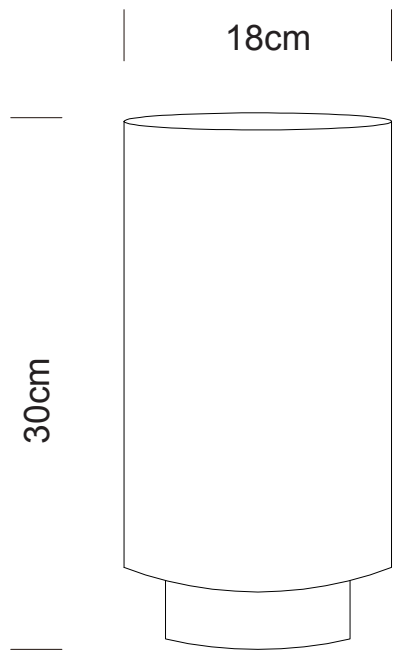

PINERAI





PINERA II

NUDO CONTINUO RUECA

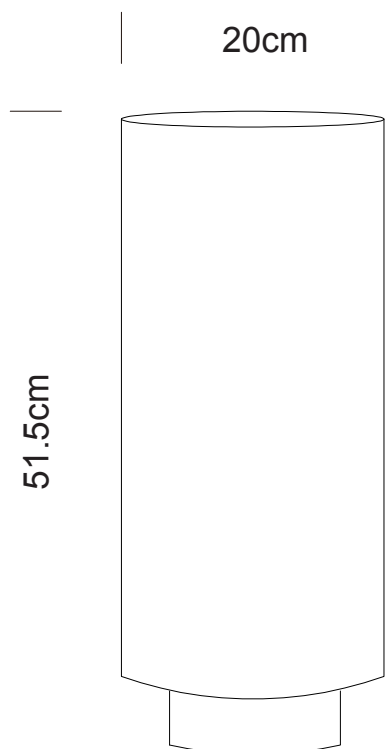



CORDÓN IRREGULAR EN NEGRO



PINERA III



CORDÓN TRENZADO EN CRUDO



ESPACIADO EN AGAVE

CONTACTO

(+52) 33 1721 7403

info@filamento.mx

@filamento.mx

